



HiPURE

FILTRATION, INC

IHF SERIES

Industrial High Flow Cartridge Housings

HPIHF Series housings robust design and high quality construction assures dependable protection for industrial and commercial applications.

PROCESS FLUIDS

- Water
(Fresh/Sea/R.O./D.I/Waste)
- Desalination
- Power Generation
- Chemicals
- Oils
- Coolants
- Food & Beverage
- Pulp & Paper

OPTIONS

- Tri-Clamp/DIN Flanges/Victaulic connections
- Seal materials (Viton, Buna, Encapsulated Teflon)
- Duplexing
- Custom OEM designs

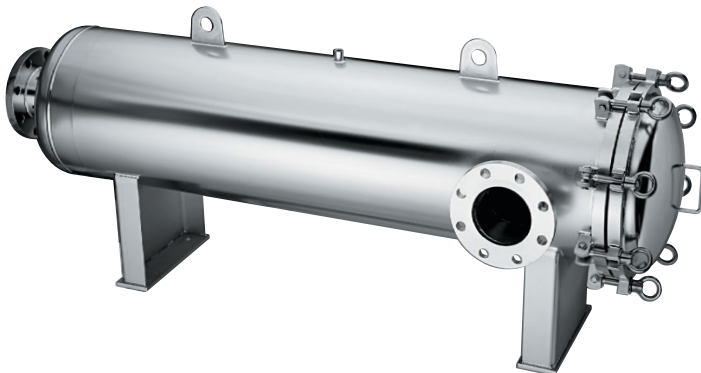

DESIGN SPECIFICATIONS

- Carbon Steel, 304SS, 316SS or 316LSS
- Swing Lid design with Eyebolt closure for dependable sealing / Davit Arm standard on larger sizes
- 150psi design pressure / 300F max temp
- Sizes to accommodate 1-19 elements (larger available)
- Accepts 40" or 60" length elements
- Designs to accept any mfg. elements, consult HiPure prior to ordering
- Inside-Out or Outside-In flow path designs available
- Differential/Drain/Vent connections standard
- Standard EPDM o-ring seal
- Finish: 2-Part Epoxy on Carbon Steel, Acid Wash with Electropolish exterior on Stainless

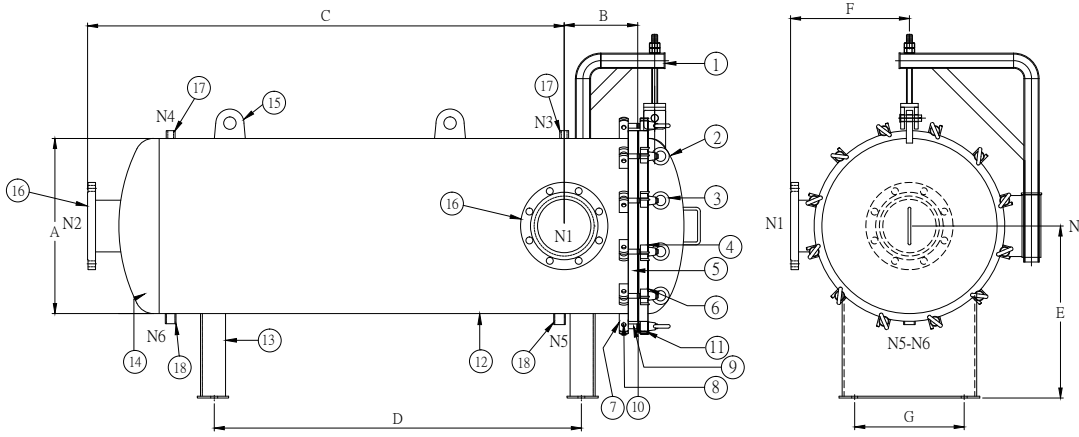

NO.	DESCRIPTION	NO.	DESCRIPTION
1.	Screw	10.	O-ring
2.	Top cover	11.	Eye nut Socket
3.	Eye nut	12.	Shell
4.	Top cover flange	13.	Support Leg
5.	Shell flange	14.	Bottom cover
6.	Washer	15.	Lug
7.	Eye bolt Socket	16.	Port(Inlet/Outlet)
8.	Spindle	17.	Vent
9.	Eye bolt	18.	Drain

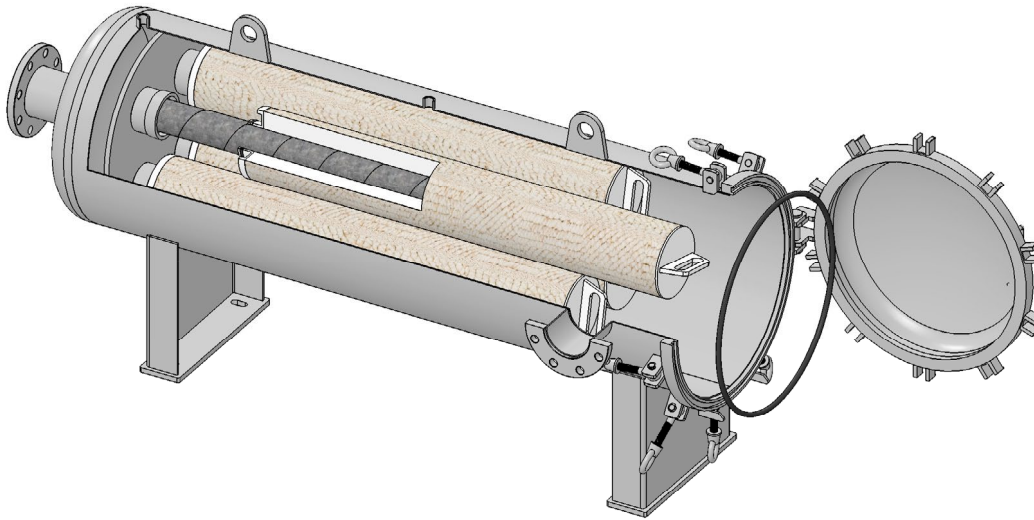

BUILDING A PART NUMBER:

(HPIHF-5-6-H-6F-4-E=(5) 60" ELEMENTS, HORIZONTAL, 6" FLANGES, 304SS, EPDM)

Series	Element Qty.	Element Length	Mounting Style	Connection Type	Material	Seal Material	Element
HPIHF	1-19	4=40"	H=Horizontal	2"-12"	C=Carbon	E=EPDM (std.)	Specify Mfg. & Model
		6=60"	V=Vertical	F=Flange	4=304SS	V=Viton	
					6=316SS	B=Buna	
					6L=316LSS	TV=Teflon/Viton	